



Introduction

Thank you for purchasing Signal Converter "VM-5011 Series".

Read this manual carefully to ensure the best performance and longest product life of the device. In addition, pay attention to the cautions described below to use the product safely.

◆Caution

- (1) Signal converter (hereinafter referred to as "converter") is a device that diagnoses various vibrations for industrial equipment such as electric motors and pumps, and consumer equipment. Do not use it for any other purpose.
- (2) **For detailed handling and specifications of the converter, please download the "Instruction Manual (Detailed Edition)" from our website and check it.**
URL: <https://we-are-imv.com/en/>

Safety Precautions

This section describes items that must be observed to prevent harm to customers and other people and damage to property, and to ensure safe use of the product. Please be sure to read this manual and attached documents before use, and fully understand the contents for use.

After reading this manual, be sure to place it in a location that you can always refer to it.

Expressions of Safety Instructions

Indication	Meaning of Indication
Warning	Indicates the contents that may cause a dangerous situation of death or serious injury if mishandled.
Caution	Indicates the contents that may cause serious injury or property damage if mishandled.
Note	Describes cases where there is no risk of injury to the operator, but it is expected to cause damage or failure to this product or other equipment or devices.

※ "Serious injuries" are those with residual aftereffects such as blindness, injury, burns, electric shock, fractures, poisoning, and those requiring hospitalization or long-term hospital visits for treatment.

◆For safe use

Warning
<ol style="list-style-type: none"> (1) Do not use this product as a life-threatening alarm device. (2) When installing near a moving part of the machine, make sure that the machine is stopped before installing it. Do not perform any installation work while the machine is in operation.

Caution
<ol style="list-style-type: none"> (1) When installing this product or peripheral devices in a high place, fix them firmly. If this product or peripheral devices fall, an accident may occur. (2) When the product is energized, do not touch the terminal block etc. carelessly.

Note
<ol style="list-style-type: none"> (1) When connecting the accelerometer to the converter, check the method that matches the specifications of the device to be connected. Improper connection may cause the product or connected devices to malfunction or be damaged. (2) Use this product in the environment described in this manual. If you use it in an environment not described in this manual, unexpected problems may occur. In addition, if the main unit is damaged or peripheral devices are damaged due to the above reasons, the warranty will be void.

Warranty

This product is shipped after strict inspection in our factory. But in case the system has a fault caused by the responsibility of IMV as the defect under production and material during the warranty period, we will repair or replace it free of charge.

The warranty period of this product is one year from the date of shipment. However, even within the warranty period, repairs will be charged in the following cases.

- (1) Any damage and breakdown caused by natural disasters such as fire, earthquake, flood, lightning damage.
- (2) Any transporting, moving, or dropping which does not relate to us after finishing our delivery.
- (3) Any error operation, unusual power supply input, and the fault caused by disassembling/repairing/modifying by customer.



1. Overview

This product is to be used to monitor vibrations constantly to confirm the safety of various rotating machines, including electric motors and pumps. This product can detect signs of abnormal operations and/or deterioration phenomena, which is utilized for the early diagnosis and maintenance.

The vibration signals of the rotating machines detected by the accelerometer are sent to the signal converter and converted into envelope acceleration (hereinafter referred to as E Acceleration) and velocity. The converter outputs the level of E Acceleration and velocity as DC current of 4 to 20mA, or DC voltage of 0 to 10V.

In addition, the signal converter outputs the vibration signal as AC voltage of 0 to 1Vrms, which can be used for analysis of the vibration waveforms.

2. Features

- (1) Simultaneous monitoring of E Acceleration and velocity levels.
- (2) Several accelerometers are available for connection to the converter.
- (3) The converter is compact and can be mounted on DIN rail.

3. System Composition

3-1. System Block Diagram

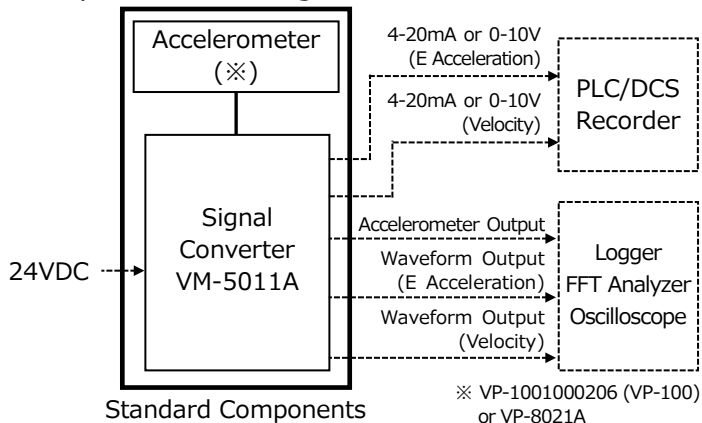

3-2. Equipment Configuration

Name	Model	Qty
Signal Converter (Converter)	VM-5011A	1
Accelerometer	VP-1001000206 (VP-100) or VP-8021A	1

Memo

- (1) Above-mentioned composition is one set.
- (2) Standard cable length of the accelerometer is 5m.
- (3) The VP-1001000206 is cable direct leading, whereas the VP-8021A comes with a cable with the connector.

4. Specifications

4-1. Specifications of the Converter

Model	VM-5011A	
Input Range	0 to 500m/s ²	
Measuring Range of Frequency	E Acceleration	10Hz to 1kHz Band Pass Filter: 500Hz to 10kHz
	Velocity	10Hz to 1kHz (ISO 2954:2012 Filter Characteristics compliant)
Measuring Range (*)	E Acceleration [m/s ² E rms]	<input type="checkbox"/> 10 <input type="checkbox"/> 25 <input checked="" type="checkbox"/> 50 <input type="checkbox"/> 100
	Velocity [mm/s rms]	<input type="checkbox"/> 10 <input type="checkbox"/> 25 <input checked="" type="checkbox"/> 50 <input type="checkbox"/> 100
Connect the Accelerometer (*)	<input checked="" type="checkbox"/> VP-100 <input type="checkbox"/> VP-8021A	
DC Output (*)	E Acceleration	<input checked="" type="checkbox"/> 4-20mA (Load 500Ω or lower) <input type="checkbox"/> 0-10V (Load 100kΩ or higher)
	Velocity	<input checked="" type="checkbox"/> 4-20mA (Load 500Ω or lower) <input type="checkbox"/> 0-10V (Load 100kΩ or higher)
	Response Speed	τ=1s 63% Response
AC Output (*)	E Acceleration	0-1Vrms (Load 100kΩ or higher)
	Velocity	0-1Vrms (Load 100kΩ or higher)
Linearity	DC Output	within ±3%F.S
	AC Output	within ±5%
The Accelerometer Waveform Output	Depend on the Accelerometer Voltage Sensitivity (Bias: 9VDC)	
Operating Temperature and Humidity Range	0 to 50°C、95%RH or less without freezing or condensation	
Suitable Cable of Terminal Block	0.2 to 2.5mm ² (AWG12 to 24)	
Power Supply	24VDC±10%	
Power Supply of the Accelerometer	24VDC 3.5mA±20%	
Power Consumption	3W or less	
Case Material	Resin	
Outer Dimensions	W22.6×H99×D113.6mm (Excluding protrusions)	
Weight	Approx. 150g	

* "■" is factory default settings.

4-2. Specifications of the Accelerometer

(1) VP-1001000206 (Cable direct leading type)

Detecting Method	Compression Type
Resonance Frequency	22kHz or more
Frequency Range	2Hz to 10kHz ±1dB
Voltage Sensitivity	10.2mV/(m/s ²) ±10%
Max Measuring Acc.	784m/s ²
Drive Current	0.5 to 8mA (18 to 30VDC)
Operating Temperature	-55 to +140°C
Protection Class	IP65
Weight	Approx. 106g (without Cable)
Case Material	SUS303
Mounting Method	M6 Screw
Cable Sheath Material	SUS Braided Cable
Outer Dimensions	φ22×H50mm (Hex 22) (Excluding protrusions and Cable)



(2) VP-8021A (Including Cable with the connector)

Detecting Method	Capacitance (MEMS) Type
Frequency Range	10Hz to 8kHz ±3dB
Voltage Sensitivity	3.9mV/(m/s ²) ±5%
Max Measuring Acc.	490m/s ²
Drive Current	3.5mA ±20% DC24V (Max.)
Operating Temperature	-30 to +120°C
Weight	Approx. 15g
Case Material	A5052 (Alumite treatment)
Mounting Method	M6 Screw
Cable Sheath Material	PVC or ETFE
Outer Dimensions	φ17×H27mm (Hex 17) (Excluding protrusions)

(2) Is the accelerometer mounting surface cleanly finished
Completely remove foreign materials such as dirt, dust, and paint. Also, make sure that the tapped holes are upright with no foreign materials on the threads.

5. Installation Method

5-1. Installation of the Accelerometer

The accelerometer detects vibration on the bottom. Therefore, it is an important condition for detecting vibration that the bottom surface is in close contact with the vibrating part.

Ideally, the surface of the equipment on which the accelerometer will be installed should be as flat as possible, and the contact surface should be coated with silicone grease or oil (Fig. 5-1).

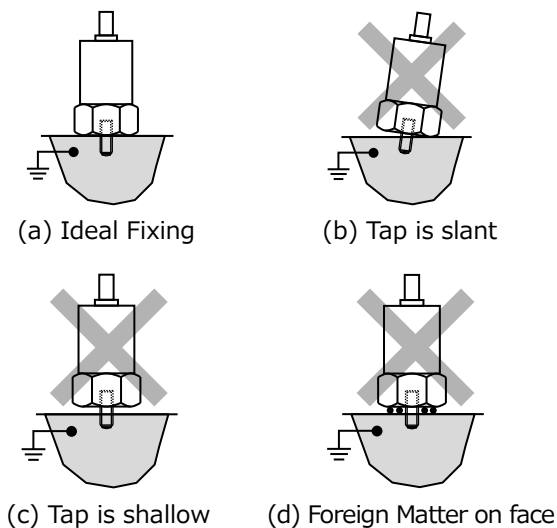

Fig.5-1 Installation of the Accelerometer

Note

Be sure to check the following items before installing the accelerometer.

- (1) Is the instrument to be measured grounded
If the accelerometer mounting surface (measurement target instrument) is not properly grounded, the accelerometer may become charged and may fail.

5-2. Laying of the Accelerometer Cable

The accelerometer cable fix away from the device to be measured and at the location closest to the accelerometer, and then fix the cable appropriately so that there is no slack.

When relaying the accelerometer cable, use a junction box, and use a twisted pair shielded cable that takes the installation environment into consideration. Also, wiring should also be kept as short as possible.

5-3. Installation of the Converter

The converter is mounted using 35mm DIN rails.

- (1) Hook the upper side of the converter body on DIN.

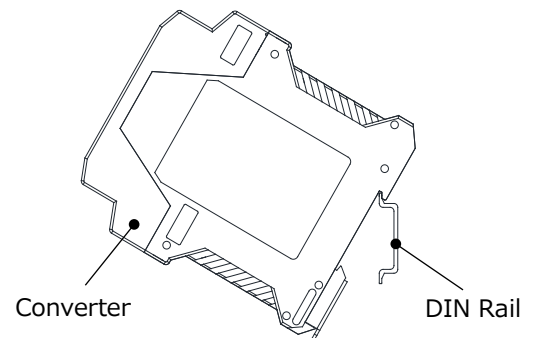

- (2) While pulling down the stopper on the lower side of the converter, hook it on the DIN rail.

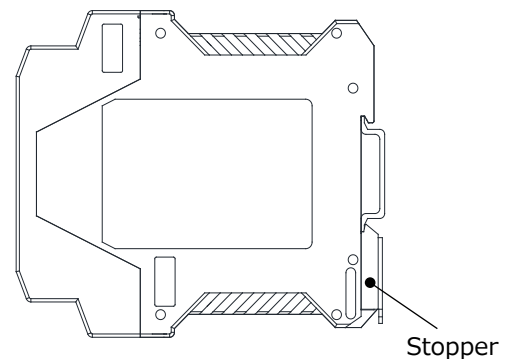

6. Wiring Method

Connect power supply, the accelerometer, and various subsequent instruments according to the wiring diagram shown on the next page.



(4) TVE-6-4165E(4)

VM-5011A Number	Use of each Terminal	How to Use
1	Pickup Input	+ (SIG)
2	Pickup Input	- (COM)
3	Pickup Input (Shield Wire)	
4	Not Normally Use	(FG)
5	Accelerometer Waveform Output	+
6	Accelerometer Waveform Output	-
7	Power 24VDC	+
8	Power 24VDC	-
9	AC Output (Velocity)	+
10	AC Output (E Acceleration)	+
11	DC Output (Velocity)	+
12	DC Output (E Acceleration)	+
13	AC Output (Velocity)	-
14	AC Output (E Acceleration)	-
15	DC Output (Velocity)	-
16	DC Output (E Acceleration)	-

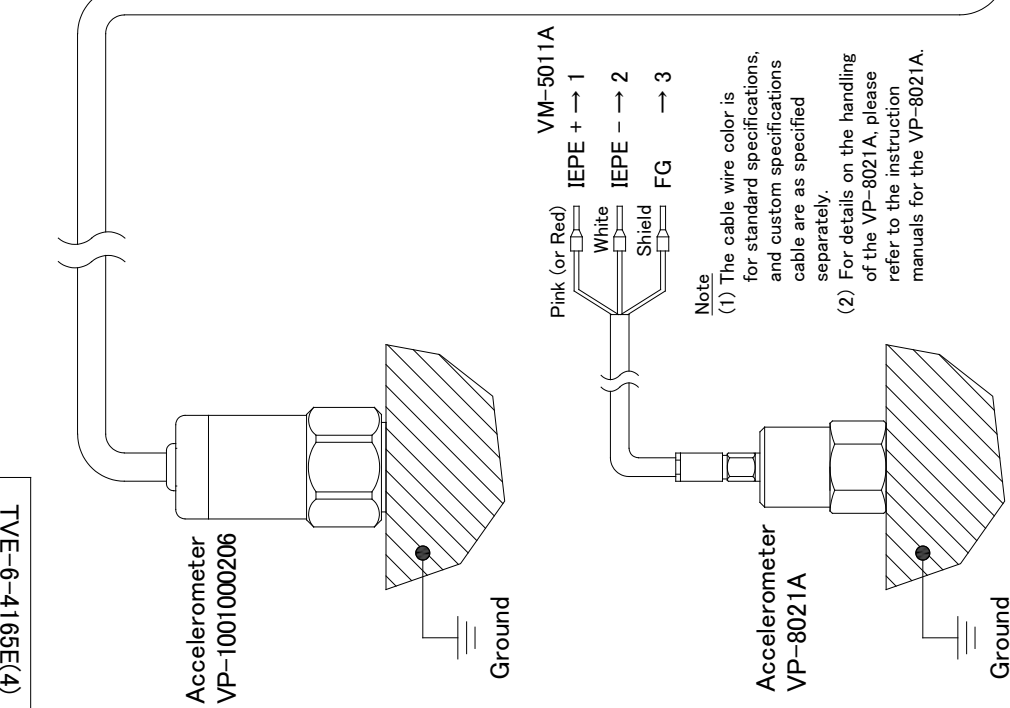
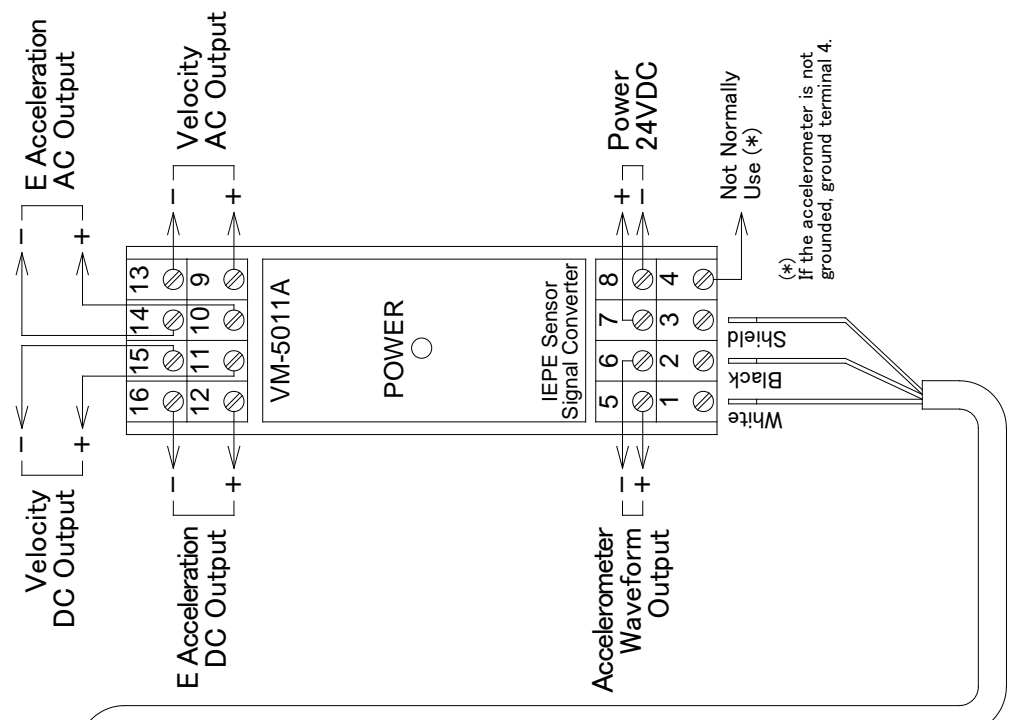

Note
(1) The cable color is for standard specifications, and custom specifications cable are as specified separately.
(2) For details on the handling of the VP-8021A, please refer to the instruction manuals for the VP-8021A.

Power Lamp Condition

OFF: Power is not supplied.
The accelerometer cable is broken.
O N: Normal (Measurement Status)

Note

(1) Details on how to handle the converter, refer to "VM-5011A Instruction Manuals (Detailed Edition)".
(2) In case of connecting the VP-8021A, it is necessary to change the jumper socket settings inside the VM-5011A. Please refer to "VM-5011A Instruction Manuals (Detailed Edition)" for how to change it.

名称 Drawing Name	VM-5011A Wiring Diagram
図番 Drawing No.	TVE-6-4165E(4)

IMV CORPORATION