



Vibration Switch

VM-90A

Standard Specifications

Pickup Type: HS-100I

(Intrinsically Safe explosion-proofing Type)

Manufacture: **IMV CORPORATION**

Specification No.: TVE-5-7739

Total page: 10



Revision

Rev0 2nd Dec,2019 New issue.

Rev1 16th Jan,2023 p5: Corrected power consumption about VM-90A from 5VA to 4VA.



<Notice>

The product comes with an instruction manual, not a standard specification or delivery specification.

Delivery specifications are available for a fee. Please inquire for details.



INDEX

1. Introduction.....	4
2. Composition.....	4
2-1. General Composition	4
2-2. System Composition	4
3. Specifications.....	5
3-1. General Specifications	5
3-2. Specifications for Vibration Switch	5
3-3. Specification of Acceleration	7
3-4. Specifications of Safety Barrier	8
4. VM-90A Connection Diagram	9
5. General.....	10
5-1. Scope of Work.....	10
5-2. Installation Site.....	10
6. Warranty	10



Standard Specifications

1. Introduction

VM-90A series are designed to monitor the vibration at all times for the safety check, detection of abnormal operation, fatigue phenomenon and maintenance of rotational machines such as turbines and blowers etc. under running.

The vibration pickup detects the vibration of turbine or blower etc. The detected signal is sent to vibration monitor and processed. Alarm circuit in it compares the signal with the preset alarm level and alarm relay operates when the signal level exceeds the preset level.

Although VM-90A is small instruments, it can select acceleration, velocity, and displacement vibration measurement.

2. Composition

2-1. General Composition

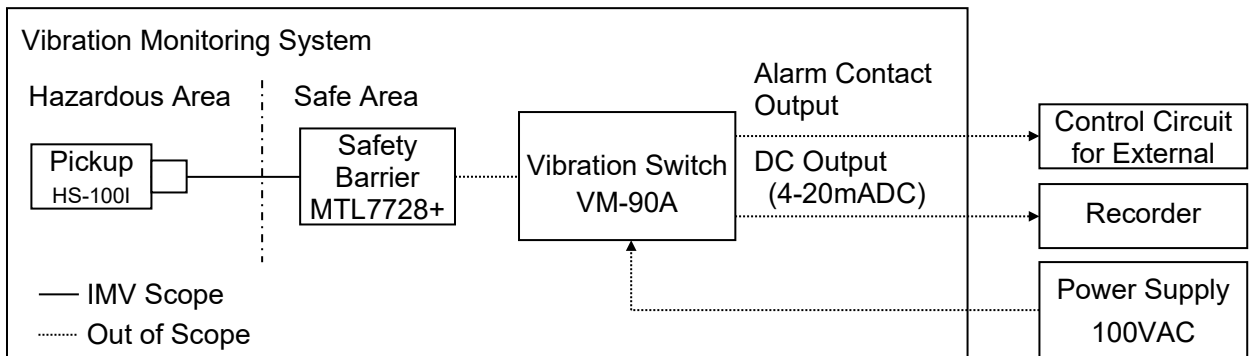

2-2. System Composition

Vibration Switch

Name	Model / Size	Qty	Note
Vibration Switch	VA-90A	1	
Vibration Pickup	HS-100I	1	
Safety Barrier	MTL7728+	1	
Pickup Cable (*1) (HS-100I - MTL7728+)	MS-AC010-5	5m 1	

Accessories

Name	Model / Size	Qty	Note
Hexagon Wrench Key	3mm	1	
Cross recessed head machine screws with washer	M3×15	4	For Vibration Switch
Small Minus Screwdriver		1	For adjusting or Setting
Instruction Manual		1	with Inspection Sheet

*1 Standard cable length is 5m. Other cable lengths please inquire for details.

*2 The above quantity is for one set.



3. Specifications

3-1. General Specifications

Measuring Frequency Range	Acceleration:	8Hz to 8kHz $\begin{matrix} +1 \\ -3 \end{matrix}$ dB (10Hz to 5kHz ± 1 dB)
	Velocity:	10Hz to 1kHz ± 1.5 dB
	Displacement:	10Hz to 300Hz ± 1.5 dB
Measuring Range	Acceleration:	10m/s ² , 100m/s ²
	Velocity:	10mm/s rms, 100mm/s rms
	Displacement:	100 μ m ^{P-P} , 1000 μ m ^{P-P}

3-2. Specifications for Vibration Switch

Alarm Output	Upper two-stage (ALARM, TRIP)
Alarm Setting Range	Any value setting of 10 to 100% to full scale range
Alarm Contact	Relay 1c Dry contact/1-Alarm
Contact Capacity	30VDC 1A (Resistance Load) 100VAC 0.3A
Delay Time	1 to 10 second
Reset Method	Automatic Reset
Rectification Level Output	4-20mADC (Maximum load resistance 300 Ω)
Monitor Output	3VAC (Peak to Peak) / Full-scale range 2VDC / Full-scale range
Power Supply	100VAC ± 10 V 47 to 63Hz
Power Consumption	Less than 4VA
Operational Environmental	0 to 50°C 35 to 95%RH (No-condensation)
Dimensions	W74×H90×D72mm Mounting Pitch : 60×82, four 3.5-Diameter holes
Weight	Approximately 250g



Outer Dimension of Vibration Switch

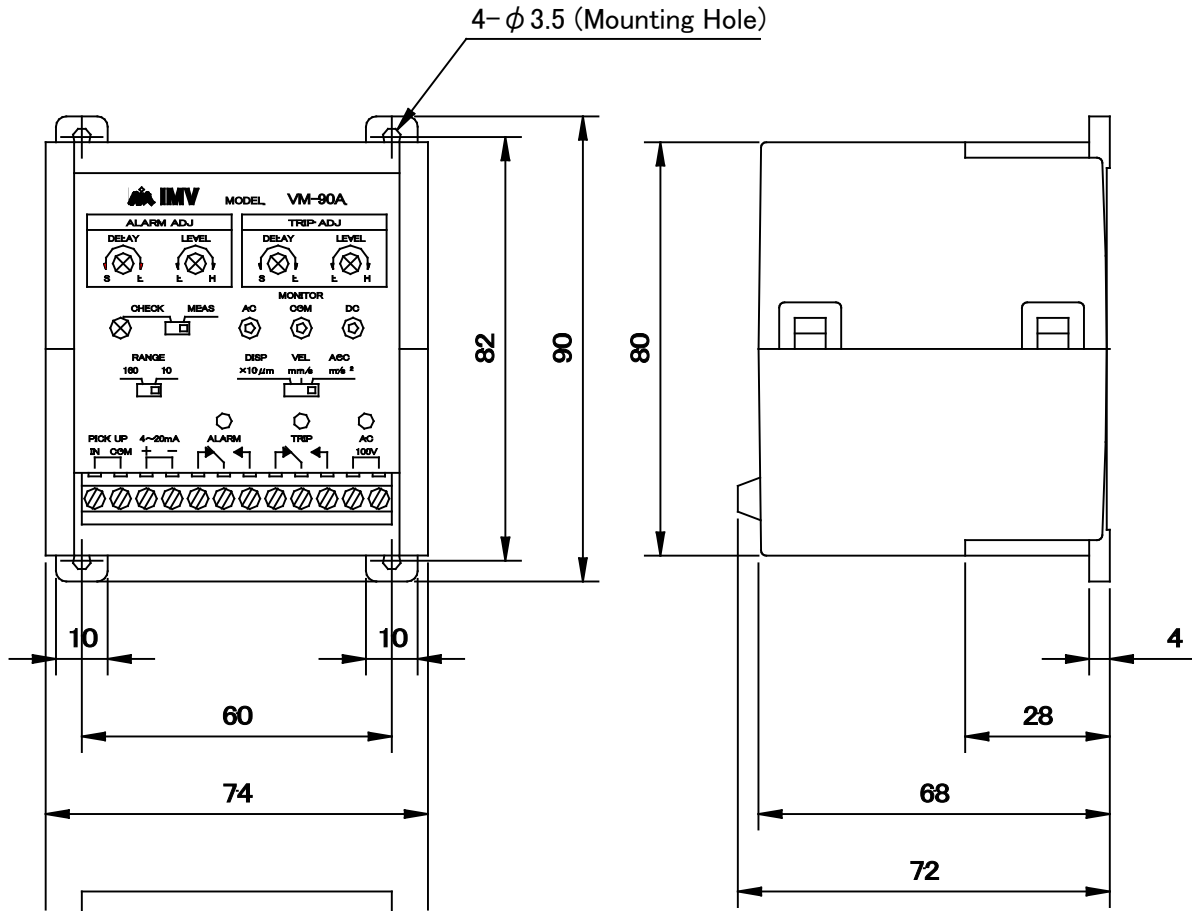

Mounting Pitch Drawing for VM-90A

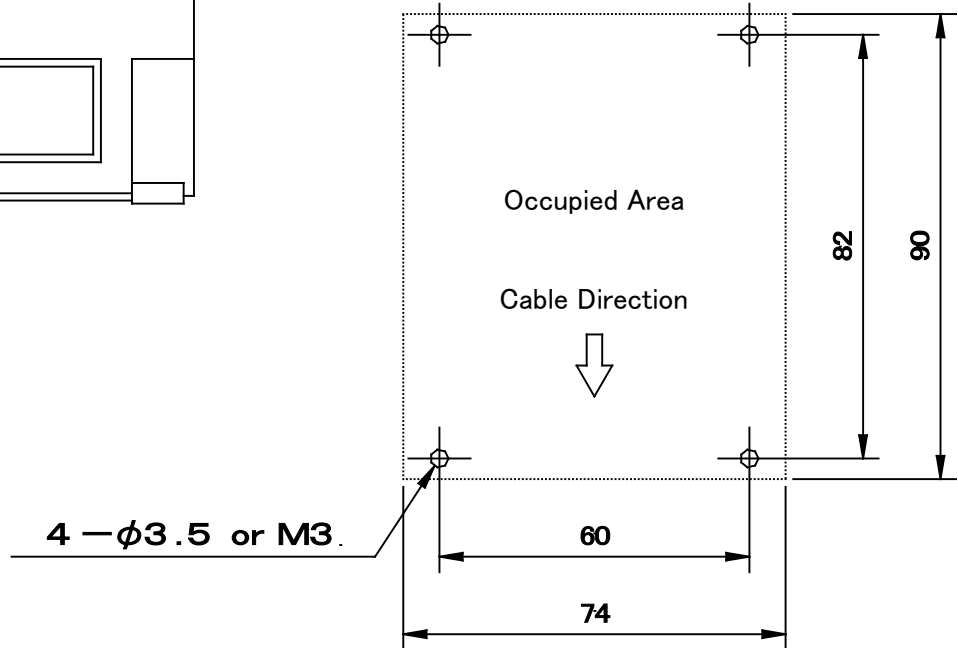

FC0038-H2



3-3. Specification of Acceleration

Model:	HS-100I
Method	PZT/Compressing
Resonant Frequency:	32,000Hz
Frequency Response:	2 to 10,000Hz $\pm 5\%$
Sensitivity:	50mV/G $\pm 10\%$ at 80Hz
Maximum Shock:	5000G
Maximum Range:	± 160 G
Power Supply:	0.5 to 8mA, 18 to 30VDC
Output Impedance:	200 Ω max
Ambient Temperature:	-55 to +110°C
Structure:	Intrinsically Safe Structure Ex ia IIC T4 Ga IECEX BAS07.0035X
Inner Capacitance:	1.0nF
Inner Inductance:	Zero
Cable connection:	M12 Connector
Weight:	106g (nominal) body only
Material:	Stainless Steel (SUS303)
Dimensions:	Below Figure
Manufacturer:	Hansford Sensors Ltd

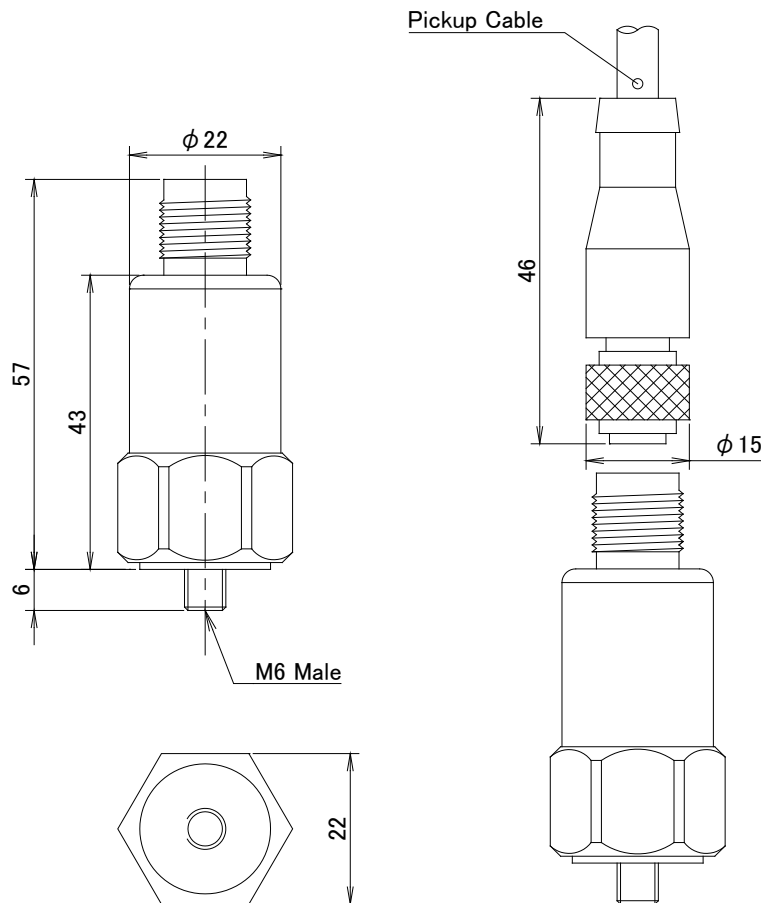

Notice!

About HS-100I specifications, Hansford Sensors documents take precedence over this document.



3-4. Specifications of Safety Barrier

Model:	MTL7728+		
Non-safe Circuit allowance voltage:	V _{max} : 250VAC, 250VDC		
Intrinsically Safe Circuit:	Allowance Current:	I _{cc}	93mA
	Allowance Voltage:	V _{max}	28V
	Allowance Power:	P _{max}	0.65W
Working Current and Voltage:	26.5V at 20mA		
Allowance Capacitance:	0.083μF		
Allowance Inductance:	3.05mH		
Explosion Class:	[Ex ia] IIC		
Dimension:	Below figure		

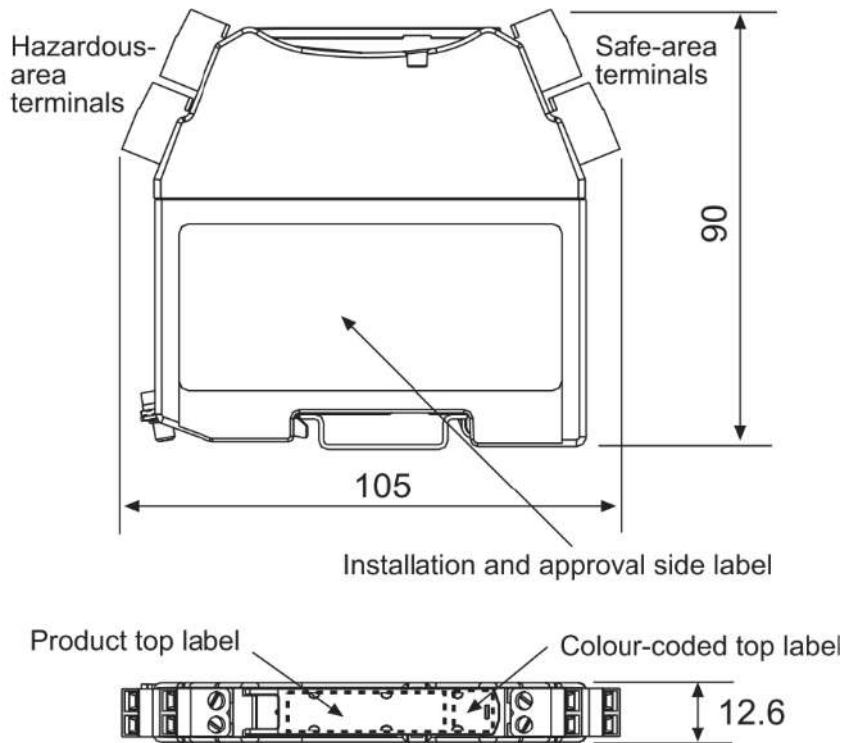

Top label background colour codes

Red	=	positive barrier
Black	=	negative barrier
Grey	=	ac barrier
White	=	dummy barrier
Orange	=	power feed module

Notice!

About MTL7728+ specifications, EATON Corporation's documents take precedence over this document.

Also, installing of safety barrier, please refer to EATON Corporation's instruction manuals.



4. VM-90A Connection Diagram

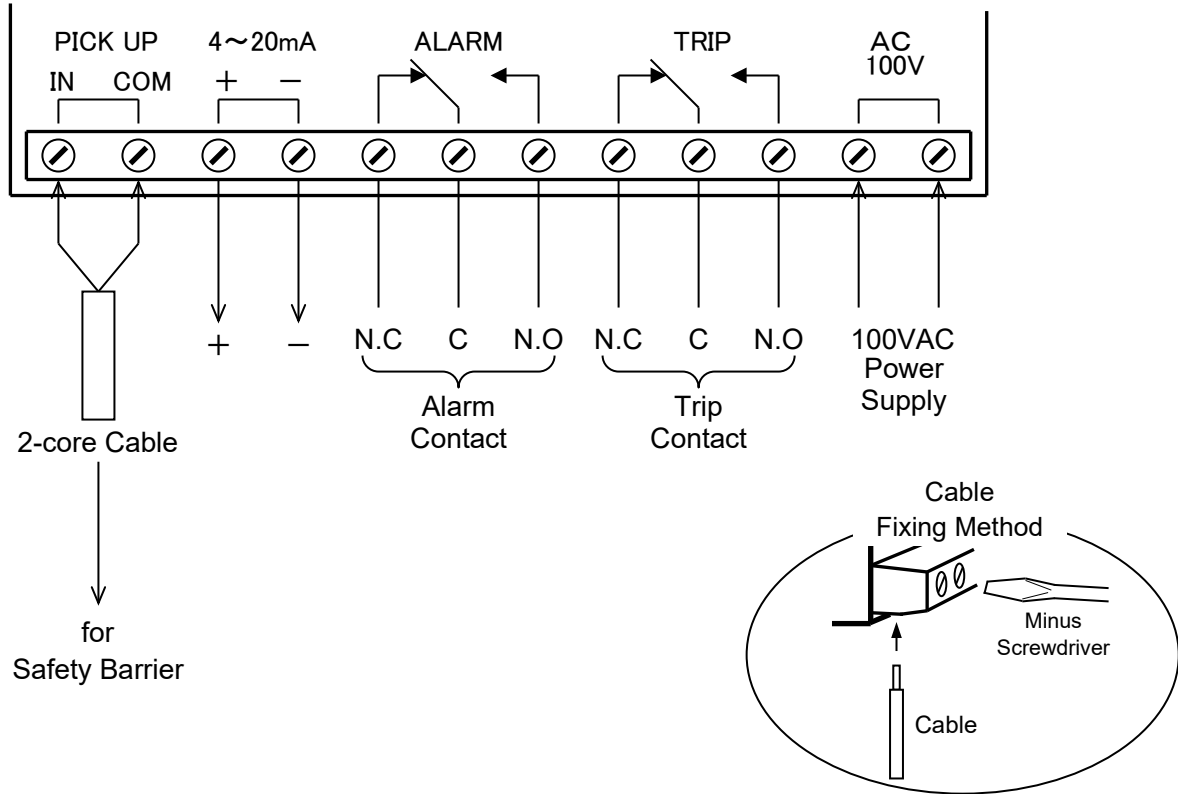

Note

Pickup cable wire color is standard.
In the case of custom specifications, it may be changed.

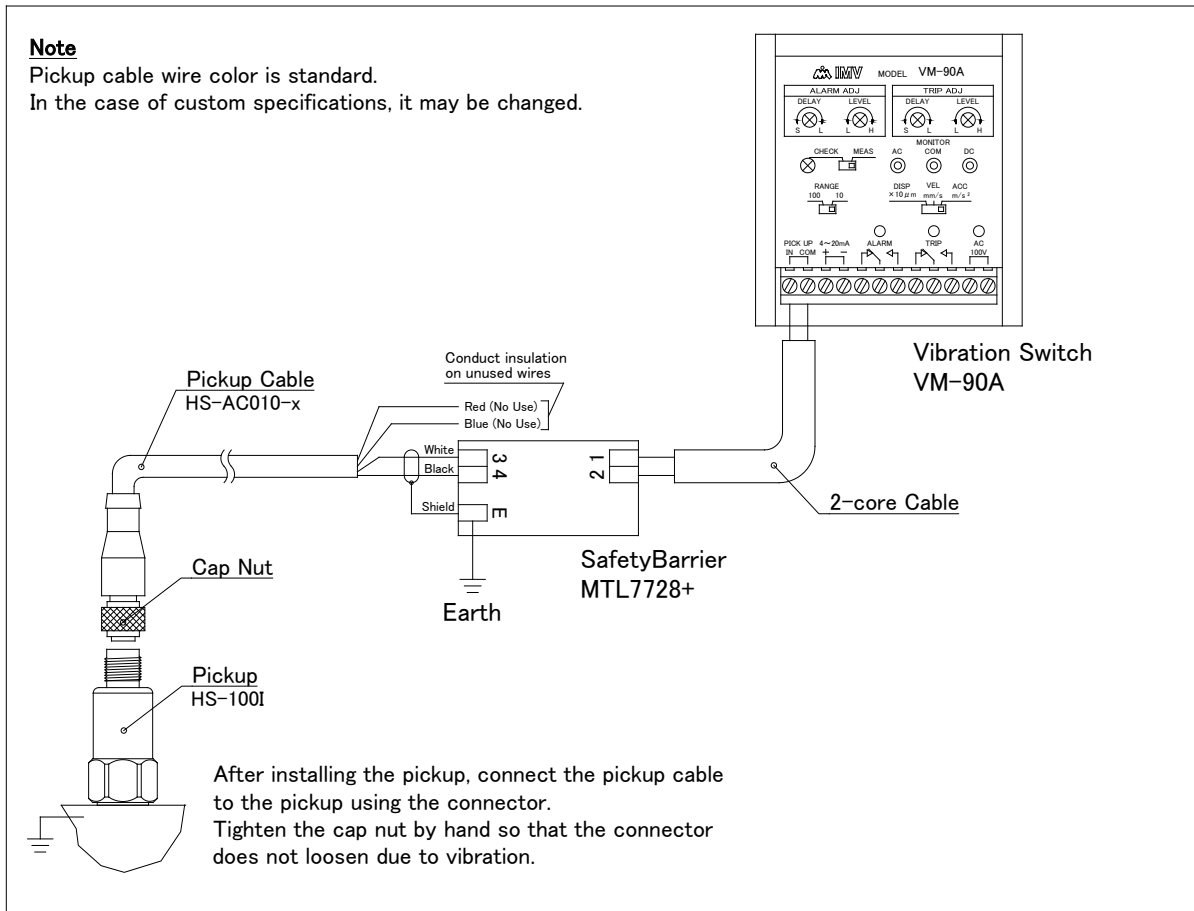



5. General

5-1. Scope of Work

Scope of work for electrical facilities, piping work and panel between customer and IMV is as follows. But special work other than mentioned below, acceptance test and change of specifications will be mentioned on special specifications after the separate arrangement.

Customer work scope:

Commercial power supply, Wiring, Piping, System installation, Connection and related work

IMV work scope:

Production of the unit and Carrying into directed place

5-2. Installation Site

- (1) The ambient condition of installation site is temperature 0 to 50°C, humidity 0 to 85%RH.
- (2) Keep away from dusty place.
- (3) Please specify the installation place.
- (4) Fix it on the concrete which has no hollow under it.

Note: Other specification will be described in Special specifications.

6. Warranty

If there is any breakdown caused by producing error, material fault, or obviously our fault, we repair or exchange with no charge. This condition is valid only in warranty term and the term is for 1 year after delivered. However, even if it is under warranty, it will occur some charge on exchanging.

- (A) Any damage and breakdown caused by natural disaster such as fire, earthquake, flood, lightning damage.
- (B) Any transporting, moving, or dropping which does not related us after finishing our delivery.
- (C) Any error operation, unusual power supply input, and the fault caused by disassembling/repairing/modifying by customer.